

# DEUTZ TCD 2.9



## TCO-optimized solutions for highest emission requirements

	TCD 2.9	TCD 2.9 HT	TCD 2.9 HP
▪ Max. power:	55,4 kW (2200 rpm)	55,4 kW (2200 rpm)	77 kW (2200 rpm)
▪ Max. torque:	300 Nm (1600 rpm)	375 Nm (1400 rpm)	420 Nm (1600 rpm)
▪ EAT:	DOC / DPF	DOC / DPF	DOC / DPF + SCR



[www.intermat.deutz.com](http://www.intermat.deutz.com)

# DEUTZ TCD 2.9



## Engine Concept Stage V

### Engine specification

No. of Cylinders		4
Displacement	l	2.92
Max. Nominal Speed	min <sup>-1</sup>	2600
Aspiration		Turbocharger with charger air cooler
Power Output acc. ISO 14396	kW	77
At Speed	min <sup>-1</sup>	2200
Max. Torque	Nm	420
At Speed	min <sup>-1</sup>	1600
Specific Fuel Consumption	g/kWh	213
Weight (DIN 70020 Part 7A)	kg	305
PTO C	Nm	120
B10T	h	8000
Service Interval	h	500 (standard) / 1000 (optional)

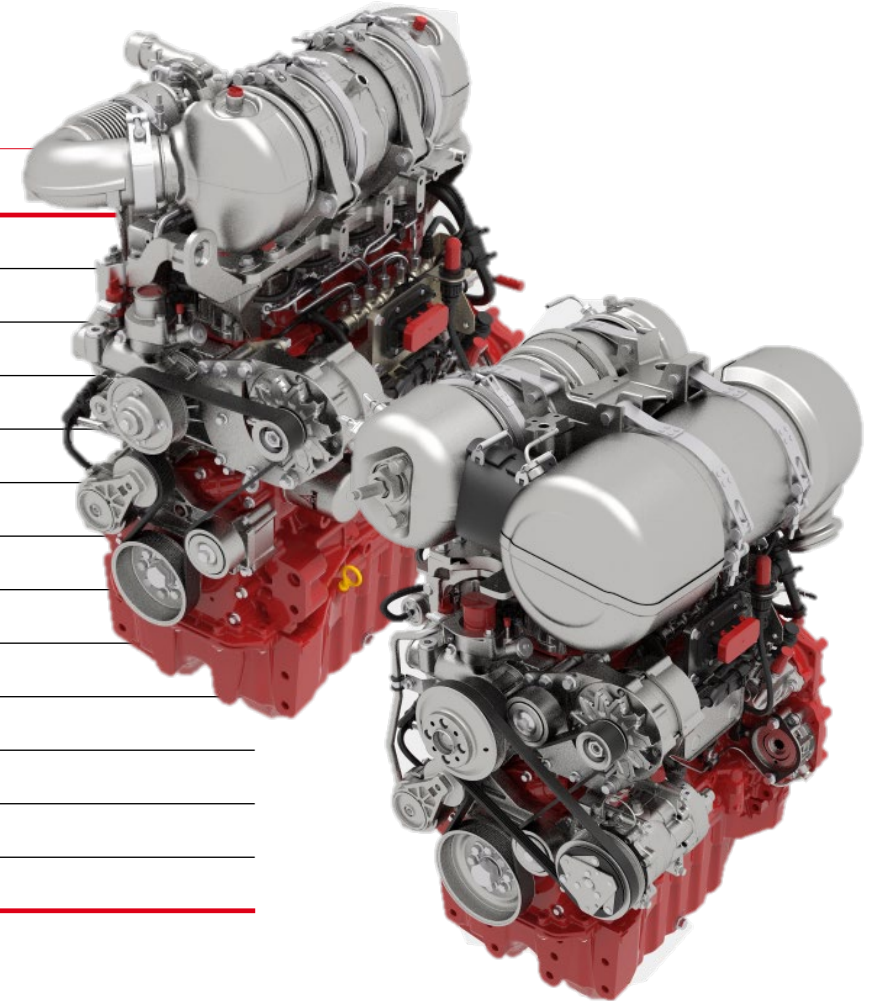

# DEUTZ TCD 2.9



## Performance Curves EU Stage V

Power

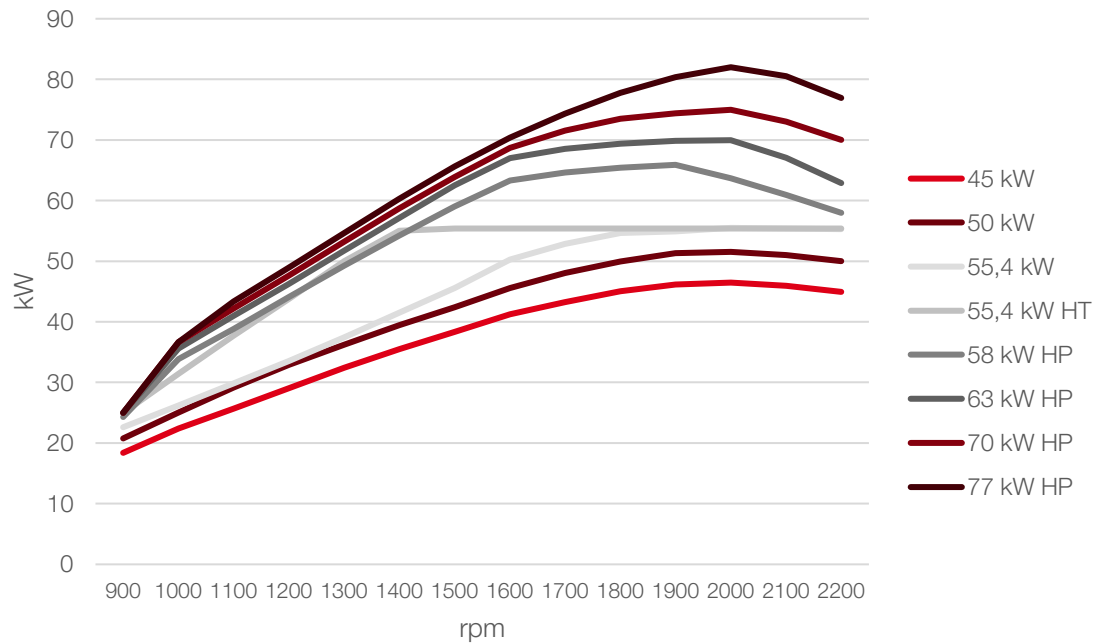

Torque

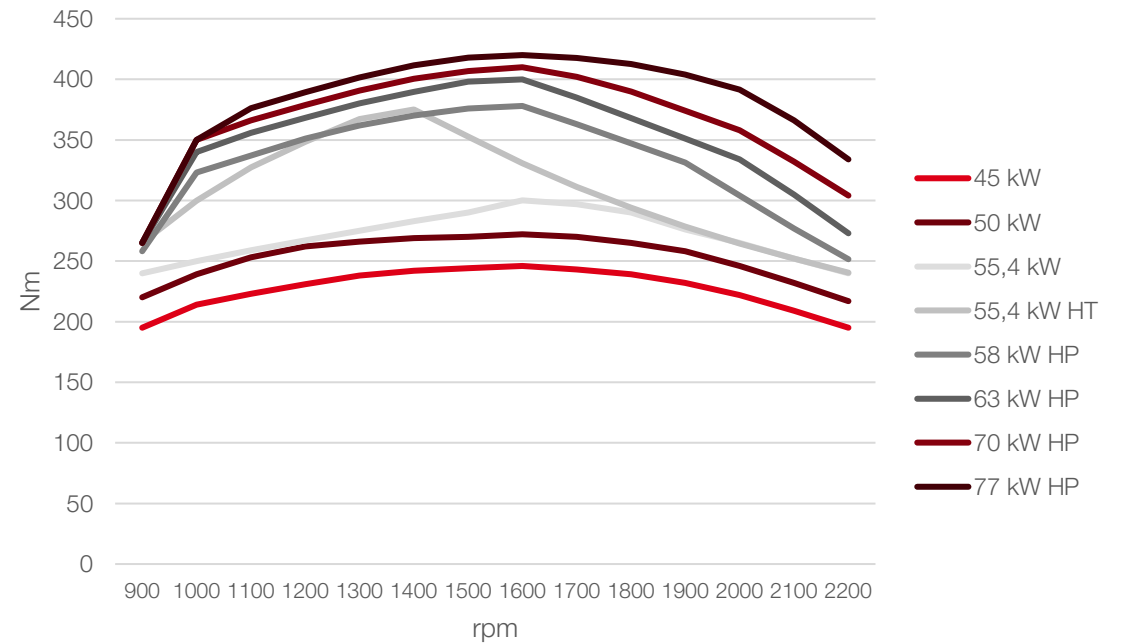

# DEUTZ TCD 2.9



## Family concept: Exhaust Aftertreatment

<b>kW Range</b>	<b>Engine</b>	<b>DOC/DPF L x d [mm]</b>	<b>SCR L x d [mm]</b>
45 - <56 kW	TCD 2.9	470 x 199	w/o
56 - 77 kW	TCD 2.9	612 x 199	267 x 781

Compact EAT >56 kW

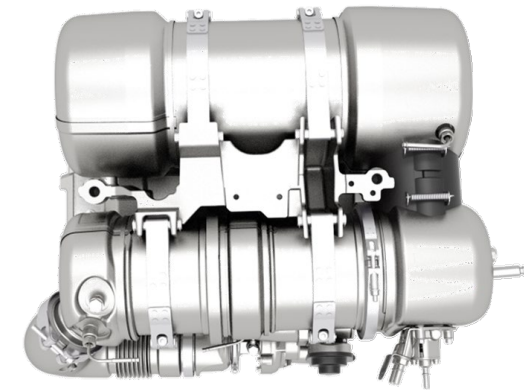

Mounted EAT <56 kW

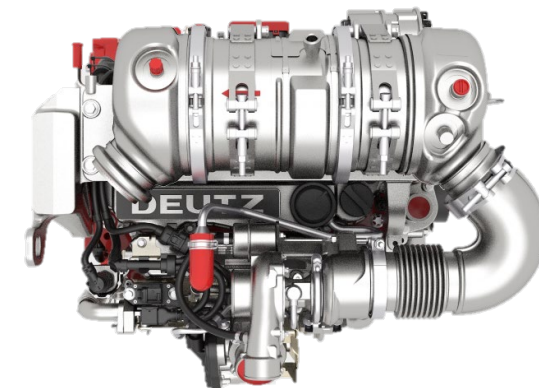

DOC/DPF

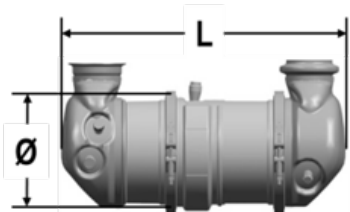

DOC/DPF +SCR

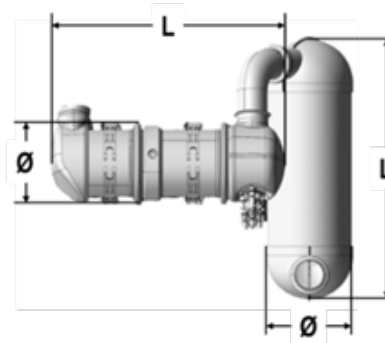

# DEUTZ TCD 2.9



TCD 2.9 >56 kW with mounted Compact DOC/DPF & SCR over valve cover

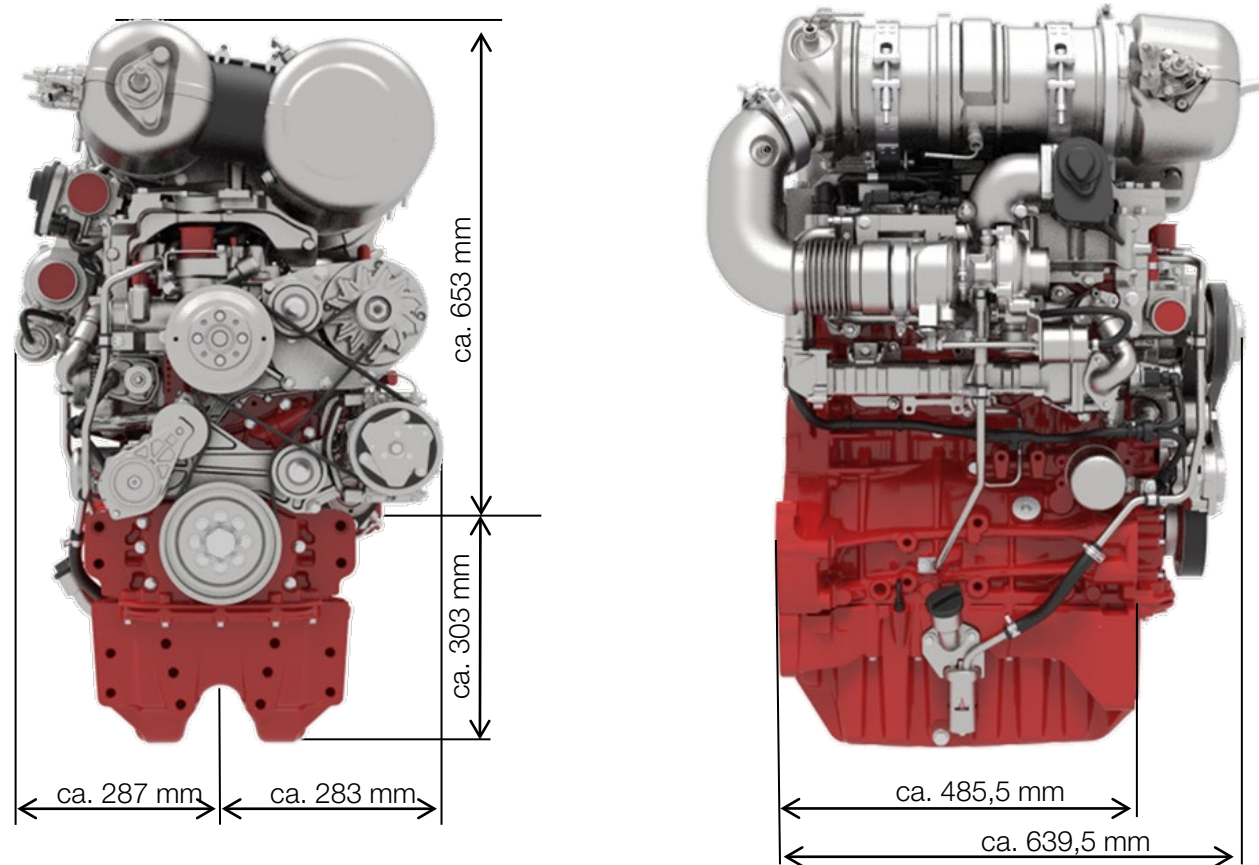



# DEUTZ TCD 2.9



TCD 2.9 <56 kW with mounted DOC/DPF over valve cover

